

Job Name : \_\_\_\_\_  
 Purchaser : \_\_\_\_\_  
 Engineer : \_\_\_\_\_  
 Submitted To : \_\_\_\_\_  
 Submitted By : \_\_\_\_\_  
 Unit Designation : Schedule No.: \_\_\_\_\_

Location : \_\_\_\_\_  
 P.O. No. : \_\_\_\_\_  
 Architect : \_\_\_\_\_  
 Date : \_\_\_\_\_  
 For :  Reference  Approval  Construction  
 Model No.: \_\_\_\_\_

**Submittal Data : LA121HNP**



**Capacities :**

Cooling ..... 11,500 Btu/h  
 Heating ..... 11,500 Btu/h  
 Outdoor Design Temp. (°F, DB/WB)  
 Cooling ..... 95/75  
 Heating ..... 47/43  
 SEER ..... 13  
 EER ..... 10.5  
 COP ..... 3.06

**Indoor Unit :**

Power Supply (V,Ph,Hz) ..... 36V DC  
 Maximum Fuse Size ..... Powered by  
 Minimum Ampacity ..... Outdoor Unit  
 Weight (lbs) ..... 33.1  
 Sound (dB(A),H/M/L Cool) ..... 41/35/29  
 Air Circulation (CFM) ..... 330  
 Dehumidification (pts/hr) ..... 3.0

**Outdoor Unit :**

Power Supply (V,Ph,Hz) ..... 115,1,60  
 Maximum Fuse Size ..... 20  
 Minimum Ampacity ..... 10  
 Weight (lbs) ..... 70.5  
 Sound (dB(A), High Cool) ..... 48

**Refrigerant Piping :**

Maximum Length (ft) ..... 50  
 Maximum Height Difference (ft) ..... 25  
 Liquid Side (O.D) ..... 1/4"  
 Gas Side (O.D) ..... 1/2"

**Standard Features :**

- Five Year Compressor Warranty
- Three Year Functional Parts Warranty
- Customizable Art Panel
- R-410a Refrigerant
- Plasma Air Purifying System
- Chaos Swing Air Circulation
- Jet Cool™
- LCD Wireless Remote Controller
- Auto Restart
- 24 Hour On/Off Timer

**Note :**

**LAN121HNP**

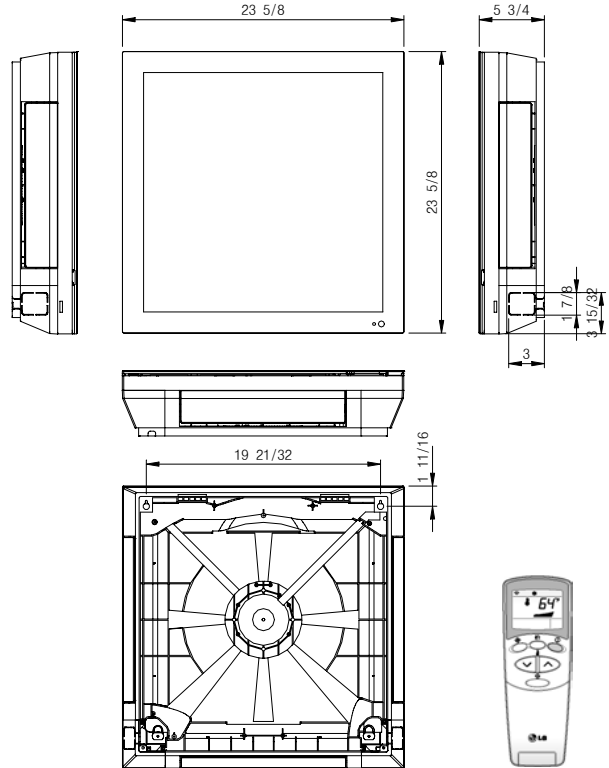

**LAU121HNP**

