



If you enjoy soaking in a warm, soothing tub surrounded by gently moving water, or if you prefer an invigorating foot and back massage, the Elara™ tub is right for you.

whirlpool features:

- Multi-speed motor
- 4 fully adjustable TheraPro® jets
- 8 AccuPro™ back and foot jets
- 900 watt variable speed heated air blower
- Bottom air channels for maximum massage
- Chromatherapy™ lighting system capable of 256 colors
- All-in-one electronic control panel
- Drain-assist purge system
- Water level sensor
- Flexible installation drop-in or undermount options
- RapidHeat™ inline heater
- Low profile deck
- ProO₃™ Cleansing System

elara™ 7242 salon™ spa

model number: DX50 - RH

exterior dimensions:

72" long x 42" wide x 26" high

of Jets/type of Jets:

4 TheraPro™

6 AccuPro™ Back Jets

2 AccuPro™ Foot Jets

operating gallons:

100 gallons



Ordering Information

Product Code:

DX50 Elara 7242 Salon™ Spa with Chromatherapy Right Hand

- Right Hand Drain Location
- Accessories / Hardware:
 - TheraPro™ Jet Rings Kit: #D095
 - AccuPro™ 2 Jet Rings Kit: # J869*
 - Sch 40, Rotary Drain Kit: #DA34
- Trim Kit Finishes Available:
 - (827) - Chrome
 - (898) - Brushed Chrome
 - (815) - Satin Nickel
 - (829) - Bright Brass
 - (805) - Platinum
 - (826) - Brushed Nickel
 - (845) - Oil Rubbed Bronze

Installation Notes

Refer to installation instructions included with fixture before beginning installation. Please confirm product availability and specifications before commencing with any installation work.

PRODUCT SPECIFICATIONS AND AVAILABILITY ARE SUBJECT TO CHANGE WITHOUT NOTICE.

Technical Specifications

Dimensions

72" L x 42" W x 26" H
(1829 mm) L x (1067 mm) W x (660 mm) H

Drain/Overflow

A: 18-1/2" (470 mm) B: 9.6" (244 mm)

Cutout

70" (1778 mm) x 40" (1016 mm) & undermount template BZ50000

Total Weight

1060 lb. (481 kg) / 51 lb/ft² (247 kg/m²)

Operating Gallonage

100 U.S. Gal. (379 Liters)
Min. 95 U.S. Gal. (360 Liters)
Max. 105 U.S. Gal. (398 Liters)

Product Weight

178 lb. (81 kg)

Skirt Mounting

Not Available

Electrical Specifications

Requires a dedicated GFCI protected separate circuit.

Blower: 120VAC, 20AMP, 60 Hz.

Motor/Pump and RapidHeat™: 240VAC, 20AMP, 60 Hz.

Heater (Standard)

Requires a dedicated GFCI protected separate circuit.

RapidHeat™: P/N BN60000

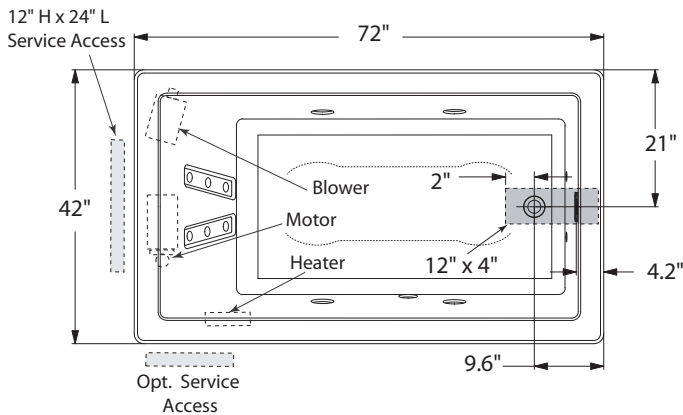

Product Shown: Elara 7242 Salon™ Spa, Right Hand Shown Model: DX50

* Measurements inside unit represent cutout in floor to allow for drain/overflow.

Minimum Service Access dimensions given.

