



Designed with easy access and comfortable bathing in mind, the Finestra™ gives new meaning to independent living. Equipped with Jacuzzi® technology and a variety of safety features, everyone can now enjoy the Jacuzzi® Home Spa Experience.™

FEATURES:

- The first and only air tight magnetic door seal
- Integral seat available in 2 heights – 14" or ADA compliant 17"
- Skirt with panels for easy installation and access
- 2 fully adjustable TheraPro® Jets
- 8 directionally adjustable AccuPro® Jets
- RapidHeat™ inline heater
- 900 watt variable speed heated air blower
- Air channels on floor and seat areas for maximum massage
- Chromatherapy lighting system featuring 256 colors
- Safety features include a grab bar and slip resistant flooring
- Pro3™ Ozone Sanitation System standard

Finestra™ 6036
WALK-IN
SALON™ SPA BATH

MODEL NUMBER:

EW35 (14" seat-LH)
EW40 (14" seat-RH)
EY70 (17" seat-LH)
EY75 (17" seat-RH)

EXTERIOR DIMENSIONS:

60" long x 36" wide x
37½" high

OF JETS/TYPE OF JETS:

8 AccuPro® Jets
2 TheraPro® Jets

OPERATING GALLONS:

70-85 gallons





Finestra™ 6036

WALK-IN SALON™ SPA BATH

EW35	Finestra™ 6036 Walk-In 14" Seat Salon™ Spa Bath, Left Hand
EW40	Finestra™ 6036 Walk-In 14" Seat Salon™ Spa Bath, Right Hand
EY70	Finestra™ 6036 Walk-In 17" Seat Salon™ Spa Bath, Left Hand
EY75	Finestra™ 6036 Walk-In 17" Seat Salon™ Spa Bath, Right Hand

- Left and Right Hand drain locations
- Accessories / Hardware:
 - Drain Kit: #FB48000
 - Remote Drain Kit: #FC30000
 - Pillow: #EK91959
- Trim Kit Finishes Available:
 - (827) – Chrome
 - (829) – Bright Brass
 - (959) – White

INSTALLATION NOTES

Refer to installation instructions included with fixture before beginning installation. Please confirm product availability and specifications before commencing with any installation work.

PRODUCT SPECIFICATIONS AND AVAILABILITY ARE SUBJECT TO CHANGE WITHOUT NOTICE.

Technical Specifications

DIMENSIONS

60" L x 36" W x 37-1/2" H
(1524 mm) L x (914 mm) W x (952.5 mm) H

DRAIN/OVERFLOW

A: 31-1/2" (800 mm) B: 6-5/8" (168 mm)

CUTOUT

NA

TOTAL WEIGHT

EW35, EW40: 370 lb. (168 kg)
EY70, EY75: 370 lb. (168 kg)

OPERATING GALLONAGE

Max: 85 U.S. Gal. (322 liters)
Min: 70 U.S. Gal. (265 liters)

PRODUCT WEIGHT

EW35, EW40: 320 lb. (145 kg)
EY70, EY75: 320 lb. (145 kg)

SKIRT MOUNTING

NA

ELECTRICAL SPECIFICATIONS

Requires two separate GFCI protected circuits.

Motor/Pump and RapidHeat™: 230 VAC, 20 AMP, 60 Hz.
Blower: 120 VAC, 15 AMP, 60 Hz.

HEATER (STANDARD)

RapidHeat™: P/N BN60000

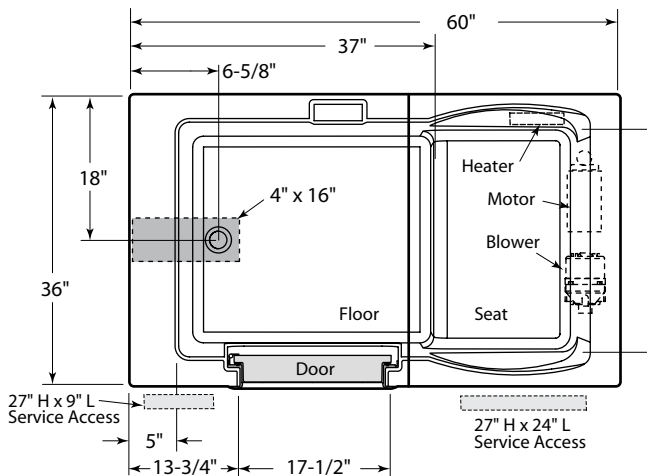

Finestra™ 6036 Walk-In 14" Seat Salon™ Spa Bath Left Hand (EW35) shown.

* Measurements inside unit represent cutout in floor to allow for drain/overflow.
Minimum service access dimensions given.

